



CP10WN



Using natural gas or propane, the CP10WN's high-efficiency generator provides 10kW of electrical power. The engine heat is captured and heats water at a rated temperature of 158°F for immediate use or storage in your facility. Excess electricity production may be sold back onto the grid in certain states, creating a credit on your electric bill.

CHP Basic Flow

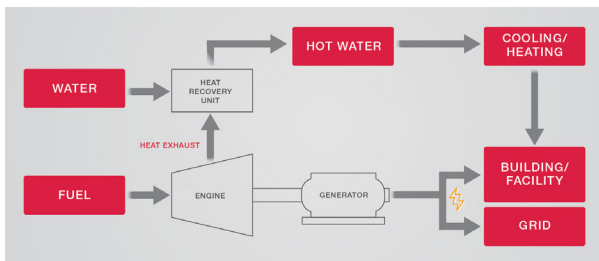

| Model | | CP10WN | | |
|----------------------------------|----------------------------------|--|---|---------------------------|
| | | CP10WN-SN (B) | CP10WN-SPB | |
| Power | Output | Rated Output | 10 kW | |
| | | Voltage | 240/120 V, 60Hz (208V, 277V) | |
| | | Phases/Wires | Single phase, 3 wire | |
| | | Modulation | 0.3 to 10 kW with optional CT/Transducer kit (*1) | |
| Fuel | Gas type | | Natural gas | Propane gas |
| | Pressure | Standard | 8 in WC (2kPa) | 11 in WC (2.8kPa) |
| | | Range | 4 ~ 10 in WC (1 ~ 2.5kPa) | 8 ~ 13 in WC (2 ~ 3.3kPa) |
| | Consumption (LHV) | | 107,500 BTU (31.5kW) | 112,800 BTU (33.1kW) |
| | | | 1.08 therms/hr | 1.34 Gallon (*3) |
| | Consumption (HHV) (*3, *4) | | 119,100 BTU (34.9 kW) | 122,800 BTU (36.0 kW) |
| | | 1.19 therms/hr | 1.34 Gallon (*3) | |
| Heat output | Rated recovered heat | | 57,300 BTU/h | 65,200 BTU/h |
| | Rated hot water temp. | Inlet | 149 F (65 C) | |
| | | Outlet | 158 F (70 C) | |
| | Rated Hot water flow rate | | 12.7 GPM (48.2 L/min) | |
| Maximum hot water temp. (Outlet) | | 172 F (78 C) | | |
| Input power | Voltage, Frequency | | 240V, 60Hz | |
| | Starting current | | 21.7 A | |
| | Power consumption | Radiator fan stop | 0.39 kW | |
| | | Radiator fan run | 0.71 kW | |
| Gross Efficiency (LHV) | Overall efficiency | | 85% | 88% |
| | Electrical generation efficiency | | 31.5% | 30% |
| | Exhaust heat recovery ratio | | 53.5% | 58% |
| Sound level | Radiator fan stopped | | 54 dB (A) | |
| | Radiator fan operating | | 56 dB (A) | |
| Dimensions | Width | | 57.9 in (1,470 mm) | |
| | Depth | | 31.5 in (800 mm) | |
| | Height | | 70.5 in (1,790 mm) | |
| | Net weight | | 1,653 lb (750 kg) | 1,664 lb (755 kg) |
| Maintenance Interval | | 10,000 hrs | | |
| Standard Warranty | | 2 Years; Unlimited Hours | | |
| YES Product Protection | 10 Years / 30,000 hrs | | Optional | |
| | 10 Years / 60,000 hrs | | Optional | |
| | 15 Years / 90,000 hrs | | Optional | |
| Emissions & Certifications | | EPA Certified UL2200 Certified CSAC22.2 No 14 Certified CSAC22.2 No 100 Certified UL1741/IEEE1547 Certified (*2) | | |

*1: The minimum modulation amount is dependent on the CT and Transducer specifications.

*2: External inverter models

*3: Propane gas calculations for fuel consumption are based on converting LHV to HHV: LHV=84,250 BTU/Gallon, HHV=91,420 BTU/Gallon

*4: Natural gas calculations for fuel consumption are based on converting LHV to HHV: LHV= 983 BTU/scf, HHV = 1,089 BTU/scf

NOTE: Due to YANMAR's ongoing commitment to quality, specifications, ratings and dimensions subject to change without notice. Improper installation, adjustment, alteration, service or maintenance can cause property damage or personal injury. Installation and service must be in accordance with current specifications, ratings and dimensions and be performed by a qualified installer and servicing agency.



CP10WN

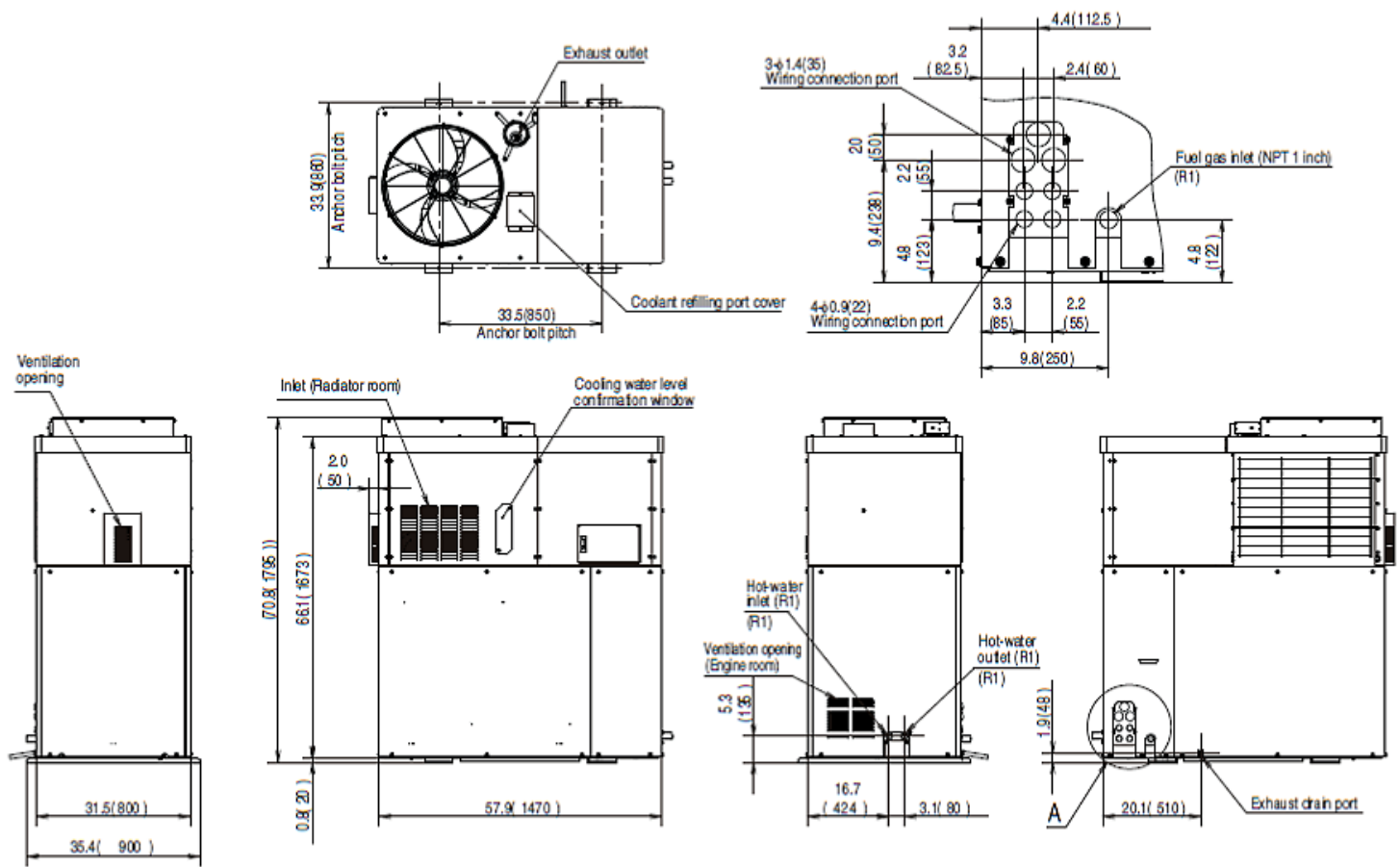

Unit:inch(mm)

NOTE: Due to YANMAR's ongoing commitment to quality, specifications, ratings and dimensions subject to change without notice. Improper installation, adjustment, alteration, service or maintenance can cause property damage or personal injury. Installation and service must be in accordance with current specifications, ratings and dimensions and be performed by a qualified installer and servicing agency.